

The Power Systems Industry Experts



Installation Instructions

PT300E Stationary Generator Monitoring System



PLEASE READ ALL INSTRUCTIONS PRIOR TO INSTALLATION

Planning the Installation

The monitoring unit should be located on a non-vibrating portion of the unit, typically inside of or near the generator control panel.

The wiring harness supplied includes 96" leads for the Battery Positive (+) and Battery Negative (-) connections. The harness also includes 48" leads for the inputs, ground leads and outputs.

The monitoring unit has an external cellular/GPS combo antenna. The antenna should be placed on top of the generator enclosure for the best cellular reception. The antenna is magnetically mounted. For generator enclosures that do not have a suitable surface to magnetically mount the antenna, a 1" heavy duty Velcro adhesive patch is supplied with the kit that can be used as needed.

Preparing for the Installation

Standard precautions should be taken prior to installing the monitoring unit. At a minimum:

- Only knowledgeable and qualified personnel should attempt to install this system
- Remove the main fuse in the generator control panel
- Remove any fuses and/or disconnect AC power to the generator (if applicable) from the ATS
- Remove/disconnect any other power source to the generator
- Proper Lock Out/Tag Out procedures should be followed

Making the Connections

Battery Connection

The PT300E harness includes a 96" **RED** Battery Positive (+) lead and a 96" **BLACK** Battery Negative (-) lead. Included are ring terminals (loose) for the Battery Positive (+) Battery Negative (-) leads. The power leads can be connected to the engine battery or to B+ and B- terminals in the generator controller. The standard monitoring program is set for a 12VDC battery system, but is capable of receiving 7-30VDC. For a 24VDC battery system, contact Power Telematics via phone or email to change the low battery alarm set point. This is done "over the air" and can be done at any time (you do not have to remain at the site).

- Connect the **BLACK** Battery Negative lead (-) on the monitor harness to the negative (-) battery terminal on the engine starting battery or another suitable B- location.
- Connect the **RED** Battery Positive lead (+) on the monitor harness to the positive (+) battery terminal on the engine starting battery or another suitable B+ location.

Do not connect the harness to the monitor or mount the monitor yet - This will be done at the end

Ignition Wire Connection

Connect the **Ignition Sensing Lead** to the fuel solenoid/engine ECU power lead or an engine run relay. This connection can be made by connecting this lead onto the connection terminal of the fuel solenoid, to the appropriate terminal on the controller or by splicing onto the fuel solenoid power lead (optional quick splice connector supplied with the kit for convenience). This lead requires a positive (+) 12/24VDC supplied to it when the engine is running.

Input Connections

For any questions on how to install the monitor, please call the Power Telematics Customer Support Team at 678-992-5501 for guidance and recommendations.

The PT300E monitoring unit has four (4) digital inputs and one (1) analog input. An input configuration data sheet is included with each monitor. This data sheet shows the programmed configuration for the monitor inputs. The inputs can be reconfigured should you choose to monitor different conditions or need to change the input bias for the controller you are connecting to. For any configuration changes, contact the Power Telematics Customer Support Team to make any changes to the programming of the monitor. Monitor programming changes can be sent “over the air”.

Digital Inputs

The digital inputs are used to signal a contact closing/opening to the monitor to send the event condition to the Power Link platform. The inputs are pre-programmed to use with a traditional normally open dry contact relay utilizing one of the ground leads supplied on the harness. Some generator controllers provide a positive voltage output on the output terminal contact on the controller. The monitor input is capable of being reprogrammed to change the bias of the input lead to receive a positive voltage to the input. In these applications, the ground lead is not required. Contact Power Telematics Customer Support to change the programming of the monitor (over the air) to correspond with the controller and outputs you are connecting to.

The PT300E has four (4) digital inputs labeled Input #1 – Input #4. There are four (4) relay ground wires that are included in the harness. Any of these ground wires can be used with the inputs for dry contact relays.

Connect the appropriate **INPUT LEAD** (see input configuration data sheet) on the harness to the normally open contact output. Connect a **BLACK** ground lead to the common terminal (other side of the normally open contact output). If the controller output is normally closed/open on alarm, contact Power Telematics Customer Support to confirm if programming changes need to be made.

See accessory kit installation instructions for any kits purchased with this monitoring system.

Common Fault Alarm Note: There is a 30 second delay for a common fault alarm to report. If you are testing the common fault alarm, be sure to leave the common fault alarm relay closed for at least 30 seconds.

Analog ADC1 Input

The primary use of the analog input channel ADC1 lead is for a common fault signal connected to a positive DC voltage (7-30VDC) lead for a fault lamp or horn when a common fault alarm relay is not available. This analog input can also be used for current sensing on large generators using the GCT kit or for an external fuel sensor when a low fuel level contact is not available on the generator. The analog input lead ADC1 accepts a positive voltage from 7-30VDC. Contact Power Telematics for when using the ADC1 input channel to coordinate the programming of this input channel.

Relay Driver Outputs

There are three (3) relay driver outputs that are available. **Output Lead #1** is used for Remote Start/Stop to provide a ground path to drive a 12VDC or 24VDC relay or close an auto-start contact. Contact the Power Telematics to coordinate programming if any relay driver outputs are used.

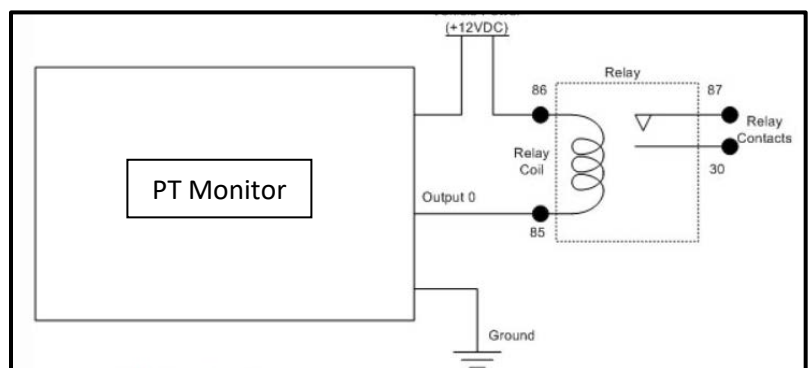

Mount the Monitor

It is best to mount and install the monitor in a vibration free location. Typically, the PT300E is best installed inside of or on the top, side or back of the generator controller. Mount the monitor using the heavy-duty Velcro patch supplied with the unit (clean the surface as needed) and place the monitor at a height so that the harness leads “hang down” to create a “moisture drip loop” to prevent moisture intrusion into the connectors on the monitoring unit.

Connect the Antenna

The cellular/GPS combo antenna should be mounted outside of and on top of the generator enclosure for the best cellular reception. Route the leads to the monitoring unit allowing for a “moisture drip loop” and connect. If you must coil the antenna leads, larger coils improve the reception signal. The antenna is magnetically mounted. For aluminum or other types of enclosures that do not have a suitable surface to magnetically mount the antenna, a 1” heavy-duty Velcro patch is supplied with the kit that can be used. For the initial “Power Up” sequence, the antenna must be outside to receive a GPS location signal or locate the monitor and to sync the local time.

Connect the harness to the monitor

Initial “Power Up” Sequence

After you have connected the harness to the monitor, the unit will go through an initial “boot up” sequence. Both the **ORANGE** light (cell) and the **GREEN** light (GPS) will flash intermittently until the sequence is complete (usually a couple of minutes), then both lights will become solid. Once **BOTH** the **ORANGE** and **GREEN** lights remain solid for at least 60 seconds, the boot up sequence is complete. Sometimes, it may be necessary to “power cycle” the monitor to reinitiate registration with the cellular network. If the **ORANGE** light remains in a flashing mode for more than 5 minutes, disconnect power to the monitor (disconnect the harness) for 10 seconds, then reconnect the power to reinitiate the process. Once both lights are solid, proceed to start and run the generator. Start and run the generator for at least 10-15 seconds, then turn it off. This will initiate a generator run signal to the monitor that will be transmitted to the user interface.

Connection “Handshake” Acknowledgement

This step is to confirm that the generator run signal and initial “handshake” with the user interface is complete. This can be accomplished via the Power Link Mobile Viewer on your smart phone/tablet or on a computer connected to the internet.

Mobile Viewer Smart Phone/Tablet Connection

Open your internet browser and go to the web site www.monitoringdatasite.com to log in. You should see the Power Link Mobile Viewer log in screen. Enter User Name and Password, then select Login. If you see the unit that you just installed listed, the “handshake” is complete. If you do not see the unit listed, verify that **BOTH** the **ORANGE** and **GREEN** lights are solid. If so, then run the generator again for 10-15 seconds, then turn the generator off. If you still do not see the unit listed after a few minutes, there may be a problem with your ignition wire connection. Verify that this lead is securely connected and run the generator again. If the unit is still not listed, call our support team for troubleshooting assistance.

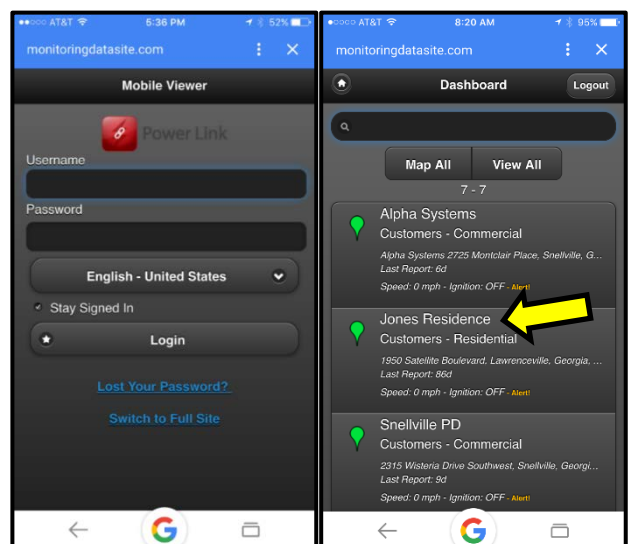

Computer Internet Connection

Open your internet browser and go to www.monitoringdatasite.com to log in. You should see the Power Link log in screen. Enter User Name and Password, then select Login. Select the **Tracking** tab. You will see the unit listed (list is sorted alphabetically). Once the unit has completed the initial “handshake” with the user interface, the Session Info Icon will change from gray to green. If the session info icon is green, and the monitor is located on the map, the “handshake” is complete.

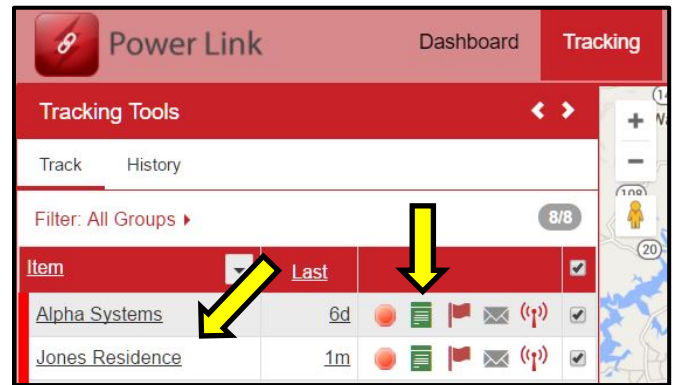

If the icon is gray, verify that **BOTH** the **ORANGE** and **GREEN** lights on the monitor are solid. If so, then run the generator again for 10-15 seconds, then turn the generator off. If you still do not see the Session Info Icon change from gray to green after a few minutes, there may be a problem with your ignition wire connection. Verify that this lead is securely connected and run the generator again. If the icon is still gray, call our support team for troubleshooting assistance.

Test Input Connections

Once the monitor is communicating with the Power Link user interface, you will be able to see the events sent from the monitor. It is a good idea to test the input connections before leaving to make sure that the inputs are wired correctly and functioning properly. Test each input and verify that the events are being received.

Mobile Viewer Verification

You can view each of these events on the mobile viewer (Select the Monitor installed and select Alerts). This will show you each of the contact events you are testing as well as the generator run/off events.

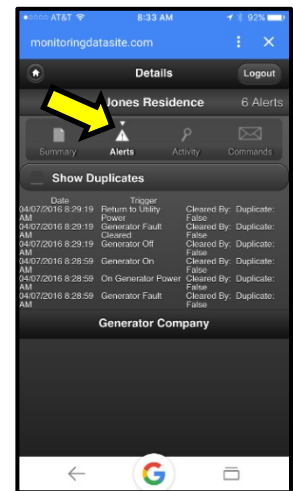

Computer/Internet Verification

You can view each of these events on the user interface. Select the **Tracking** Tab, then click on the green **Session Info Icon**. This will open the Session Info screen. Select the **Events** Tab and you should see the events created from the input verification tests as well as the generator on/off events.

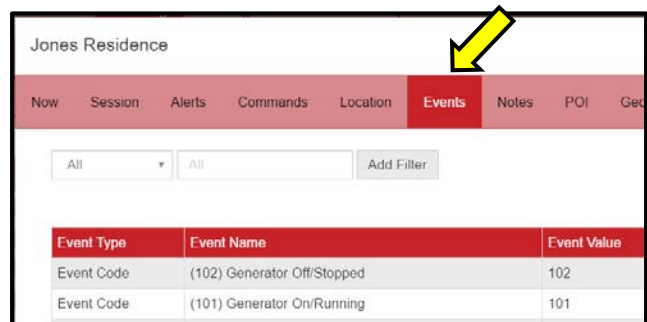
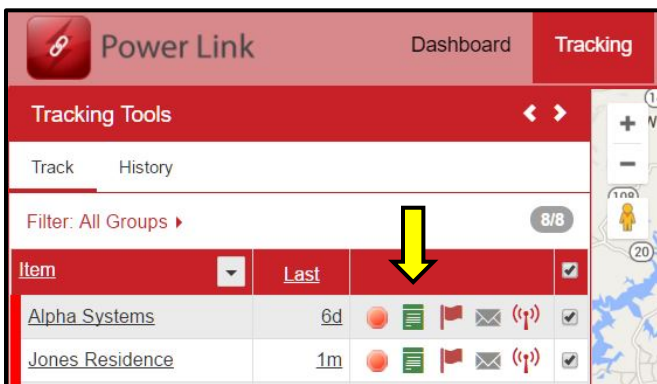

That's it...you are all set. For any questions or need any assistance, please contact our support team.

PT300E Wiring Index

PIN#	DESCRIPTION/LABEL
2	OUTPUT 0 (-)
3	INPUT 1
5	ADC 1 – Analog Input (+)
6	INPUT 3
7	INPUT 4
8	IGNITION – Engine Run 12/24VDC Input (+)
10	OUTPUT 1 (-) – Remote Start/Stop
11	OUTPUT 2 (-)
12	INPUT 2
14	PRIMARY POWER - Battery Positive (+)
15	PRIMARY POWER - Battery Negative (-)
16	GROUND - For All Relay Contact Inputs (-)

Power Telematics, Inc.

3235 Satellite Blvd, Building 400, Suite 300 | Duluth, GA 30096

Phone 678-992-5501

Email info@powertelematics.com | www.powertelematics.com